

Universal cleaning
machine TAS.
LAAC.

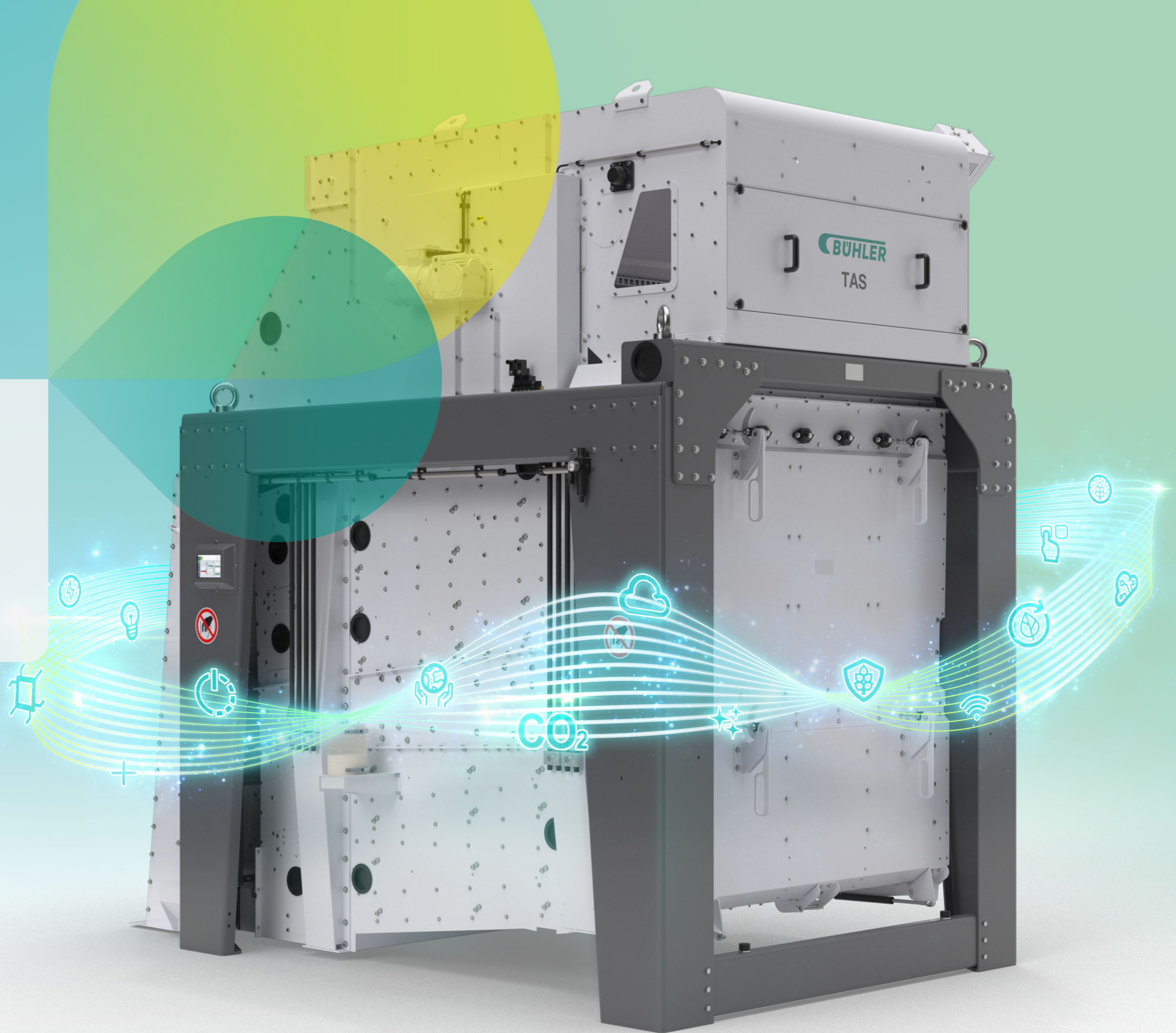

The next generation of TAS Universal Cleaner.

Full control at your fingertips.

Cleaning is one of the essential process steps for a wide range of businesses operating at intake points and milling and malting plants. With the new TAS LAAC, operators have all the controls at their fingertips wherever they are in the mill and reception points, meaning adjustments can be made with ease to optimize settings at changeovers. With the introduction of sensors, the machine is ready to connect to digital services offering condition monitoring for maximum uptime and deep analyses for improved yields.

The new generation is fitted with a package of sensors* for a multitude of functions and a user-friendly display incorporated on the machine. The main benefit of the new machine control is that operators can change settings digitally. Considering the amount of time spent on monitoring and adjusting machinery to maintain the optimum running of the plant, this is more than mere convenience- it's a whole new level of efficiency. The system is also ready to be connected to the optional Bühler Insights digital service, which provides for tracking KPIs, such as the condition of the main bearings and the setting of aspiration flaps. Advanced machine condition monitoring detects critical thresholds and reduces the risk of unplanned downtime significantly.

- + Recipe control enables targeted cleaning for improved yield and quality
- + Remote adjustment of process functions offer more convenience and labor cost savings
- + Easy-to-perform machine settings if product changes
- + Process savings, no external throttle valve required
- + Further process optimization through digital services*
- + High uptime rates thru condition monitoring services*
- + Full integration into a plant control system

*optional

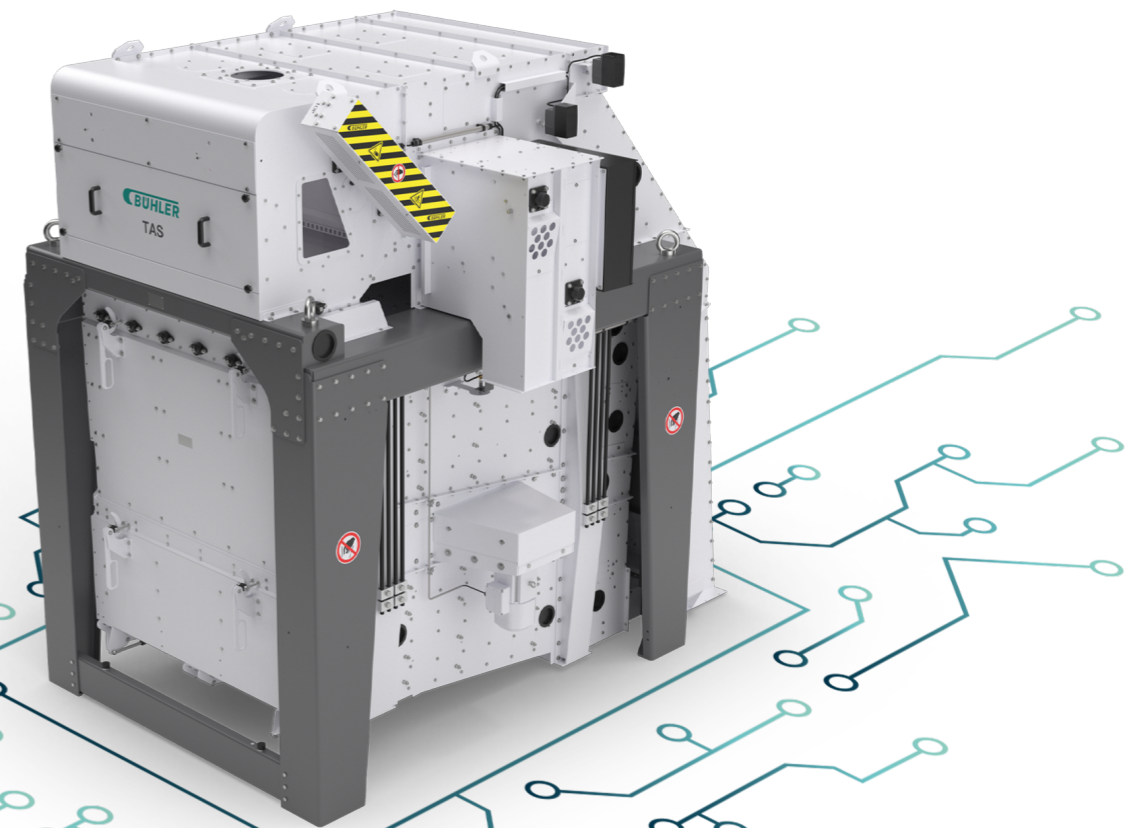

The next generation of TAS Universal Cleaner. **Taking on the challenge.**

The new LAAC isn't only ready to connect to digital services, it's also taking on the sustainability challenge. It comes with a set of optional and alternative components and can fit and match the ideal constellation of features chosen from a wide range of combinations. This modular design is environmentally friendly in itself - parts that are not needed don't have to be produced, helping to reduce CO₂ emissions and boost sustainability.

However, we've also made significant improvements to many standard components as part of lifecycle changes. Among these updates are new sealings for better dust reduction and new LED technology, which saves energy and - with a lifespan of ten years - relieves maintenance efforts. The oscillating movement is more efficient than linear alternatives, achieving excellent cleaning results with a low energy input. The twice-over use of aspiration is highly cost-effective and reduces the amount of impurities like fungi spores and others.

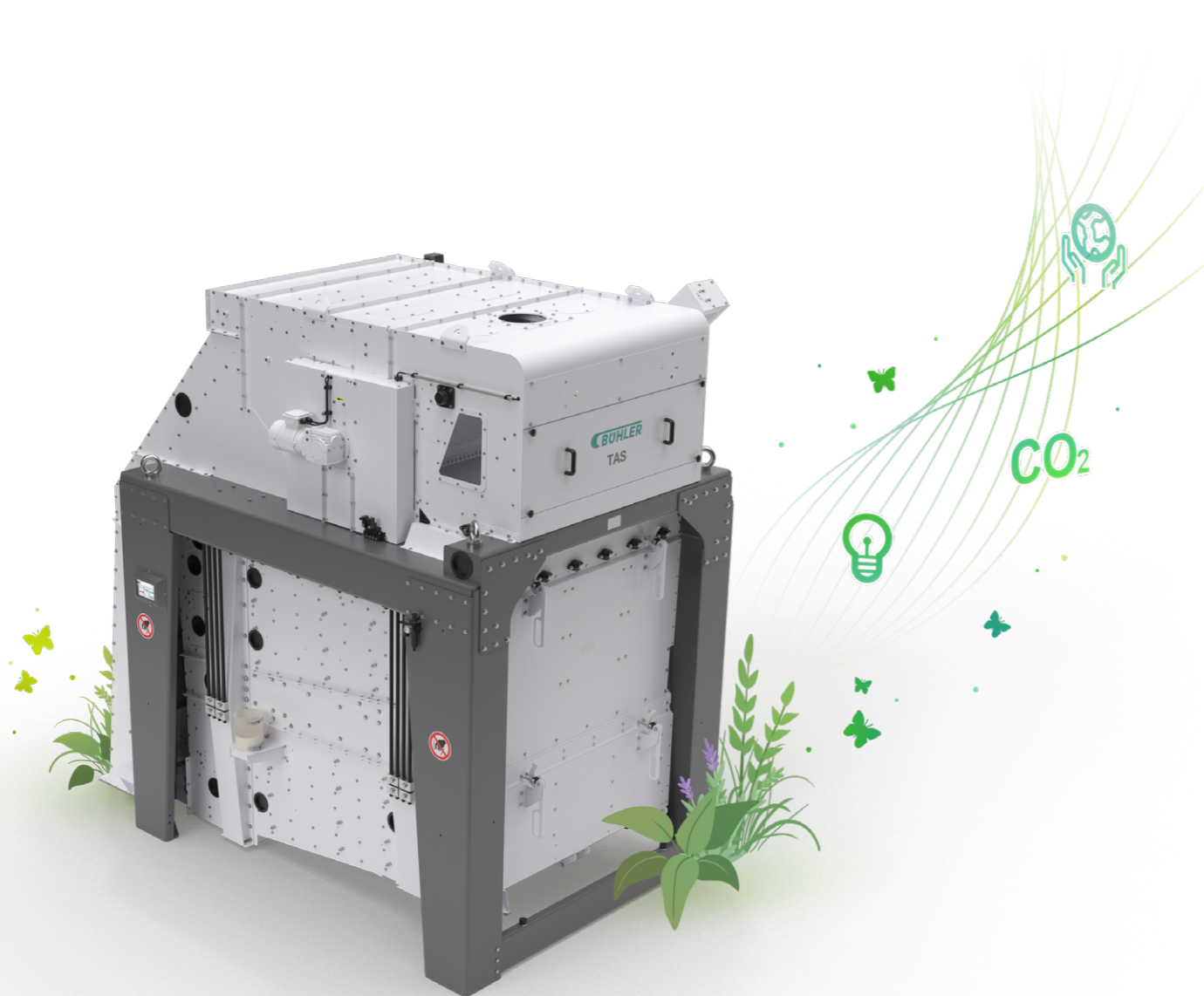

- + Reduction of waste due to fast electrical aspiration settings
- + Built-to-last machine quality
- + New LED saves energy and maintenance efforts
- + Wear protection and improved sealings for longer lifetime
- + Cost effective twice-over use of aspiration
- + Energy saving technology thru fast change of electrical settings and established sieve box movement
- + Automatic Aspiration: TAS detects good-product volume and auto-adjusts for higher yield

Introducing TAS With Automatic Aspiration

Unlock more efficiency and cost savings with the new Automatic Aspiration feature for the TAS, making the industry's benchmark cleaner even more effective. With a new system of aspiration that automatically adjusts, TAS now maintains throughput and cleaning quality, compensating for changes in your product flow automatically and without human intervention.

This smart upgrade not only ensures consistent performance but also reduces operator workload, training time, and maintenance effort. Designed for easy retrofitting on select TAS models, it enhances process stability and yield – without the need for new equipment. Here are some of the unmissable benefits:

- + **Supreme Efficiency:** Let aspiration flaps adjust automatically. The Automatic Aspiration feature optimizes airflow and yield by detecting product volume and fine-tuning the aspiration in real time.
- + **Easy Operation, Less Maintenance:** No more manual corrections. The system automatically compensates for air volume changes and pressure losses, ensuring stable performance with minimal training or upkeep.
- + **Made to Retrofit:** Upgrade your existing TAS cleaner effortlessly. The feature fits select models, boosting efficiency and performance without a full replacement.



New developments and features.

Ready to connect?

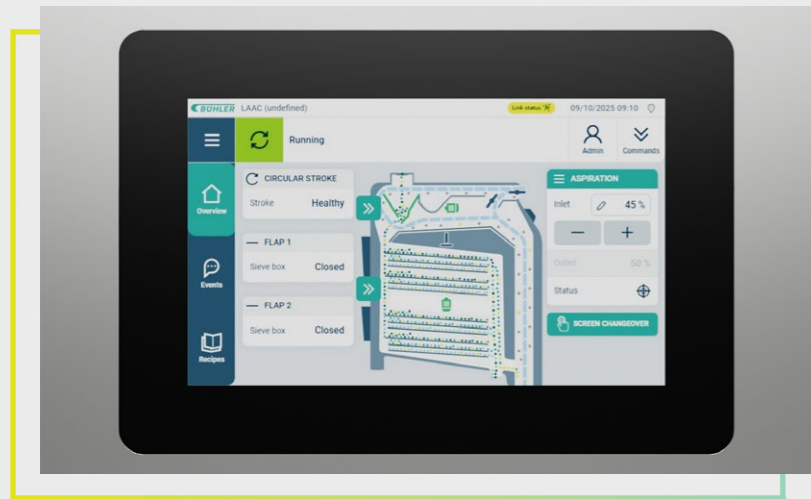

Options for intake cleaning machines

- 1 Display
- 2 Automatic inlet regulation
- 3 Electric flaps
- 4 Sensor package
- 5 Machine control
- 6 Screen changeover
- 7 Automatic Aspiration

With machine control
 Without machine control

Main aspects - highlighted

- + Convenience and saving of labor costs due to remote settings (incl. mobile devices) of process functions incl. recipe control
- + Improved yield and electrical air settings mean fewer product losses as a result of incorrect machine settings
- + Process safety/controlled settings (performance) via own machine control
- + With the new Automatic Aspiration feature, TAS automatically equalizes pressure losses, ensuring a continuous and stable process. Unlock easy installation, less training, and reduced maintenance
- + Full integration into a plant control system*
- + Optional digital services as a base for condition monitoring and further enhancement - reduced downtime risk and optimization of entire process
- + Ensures the same automation standard for cleaning as in the rest of the reception point or mill

*PROFINET required

Reception intake cleaning machines. Applicable in a large capacity range.

The TAS series is available in nine different installation sizes and can cover a very large capacity range, from 20 t/h up to a maximum of 250 t/h (for wheat cleaning). If you have specific construction requirements it's also possible to split the aspiration and the screen box (TS+AS) creating a variety of possibilities.

Intake cleaning.

The following four types of machine in the TAS series are especially recommended for an effective preliminary and main cleaning of grain and other bulk materials: **TAS 152A-2, TAS 154A-4, TAS 204A-4 and TAS 206A-6.**

The ratio of the preliminary and main sieve area is the same for all four types. The pre-screen area is particularly crucial for the use as a pre-cleaner as well as for rapeseed cleaning, whereas sufficient main-screen area is important for precise cleaning into 1st and 2nd grade.

		TAS 152A-2	TAS 154A-4	TAS 204A-4	TAS 206A-6
Max. product capacities with max 4% impurities (by weight)					
Wheat (0.75 t/m ³ , 18 % H ₂ O) PS: D 8 mm, MS: 2.25 x 23 mm	t/h	60	120	160	250
Feed Barley (0.65 t/m ³ , 18 % H ₂ O) PS: D 8 mm, MS: 2.25 x 23 mm	t/h	50	100	130	210
Corn (dry) (0.75 t/m ³ , 15 % H ₂ O) PS: D 13 mm, MS: D 5 mm	t/h	60	120	160	250
Corn (wet) (0.75 t/m ³ , 35 % H ₂ O) PS: D 13 mm, MS: blind	t/h	30	60	80	120
Canola (0.60 t/m ³ , 14 % H ₂ O) PS: D 3.5 mm, MS: 1 x 23 mm	t/h	45	90	120	180
Soybeans (0.75 t/m ³ , 18 % H ₂ O) PS: D 13 mm, MS: 2.55 x 23 mm	t/h	65	130	180	270
Operating width	mm	1,500	1,500	2,000	2,000
Screen area					
Pre-screen area	m ²	12	24	32	48
Main-screen area		6	12	16	24
Motor power					
Screen box	kW	2.2	3.0	3.0	3.0
Others		0.75-0.9*	0.75-0.9*	0.75-0.9*	0.75-0.9*
Aspiration connection					
Exhaust air (at 900 Pa)	m ³ /min	140	195	260	390
Screen box (at 300 Pa)		12	12	12	12
Total weight	kg	~ 4,800	~ 6,600	~ 7,800	~ 10,300
Dimensions (L x W x H)	m	3.30 x 2.63 x 2.50	3.42 x 2.63 x 3.30	3.42 x 3.14 x 3.30	3.70 x 3.17 x 4.35

*according to optional features

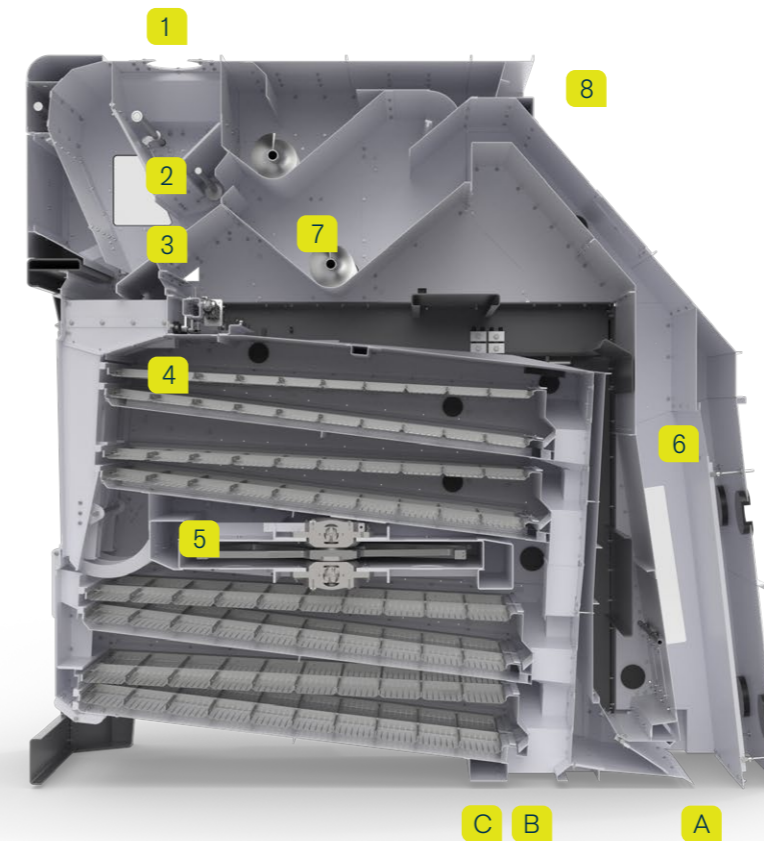

- 1 Product inlet
- 2 Vibrating inlet flap
- 3 Inlet aspiration
- 4 Product distribution onto sieves
- 5 Drive sieve box
- 6 Vertical sifter
- 7 Expansion chambers with discharge screws
- 8 Exhaust air connection

- A 1st grade
- B 2nd grade
- C Coarse particles

Processing machines.

Grading at its best.

Depending on the type of grain and the desired cleaning result, different screen perforations and sizes can be selected. All variants have one thing in common: first-class cleaning technology with maximum throughput and safe operation.

Processing.

When it comes to the reliable and precise grading of grain, especially brewing barley, these five installation sizes of the TAS processing machine series earned an excellent reputation:

TAS 153A-1, TAS 156A-1, TAS 206A-2, TAS 210A-1 and TAS 200A-III.

Due to the significantly larger main-screen area compared to the preliminary sieve, the grain can be processed very precisely and sorted into two grades. Thanks to its additional post-sieve area, the TAS 200A-III is used for three-grade sorting. All of this has meant that the TAS processing machines have become an indispensable part of successful malting and grain processing plants.

		TAS 153A-2	TAS 156A-1	TAS 206A-2	TAS 210A-1	TAS 200A-III
Max. product capacities						
Brewing barley (Main cleaning)	t/h	20	30	60	50	40
Operating width	m	1.5	1.5	2.0	2.0	2.0
Screen area						
pre-screen area	m ²	3	3	8	4	4
main-screen area	m ²	9	18	24	40	28
post-screen area	m ²					8
Dimensions (L x W x H)	m	3.30 x 2.63 x 2.50	3.42 x 2.63 x 3.04	3.42 x 3.14 x 3.57	3.42 x 3.14 x 3.57	3.42 x 3.14 x 3.57
Motor power	kW	2.2 + 0.75	3.0 + 0.75	3.0 + 0.75	3.0 + 0.75	3.0 + 0.75
Aspiration connection	m ³ /min	152	152	272	152	152

PS = pre-screen; MS = main screen

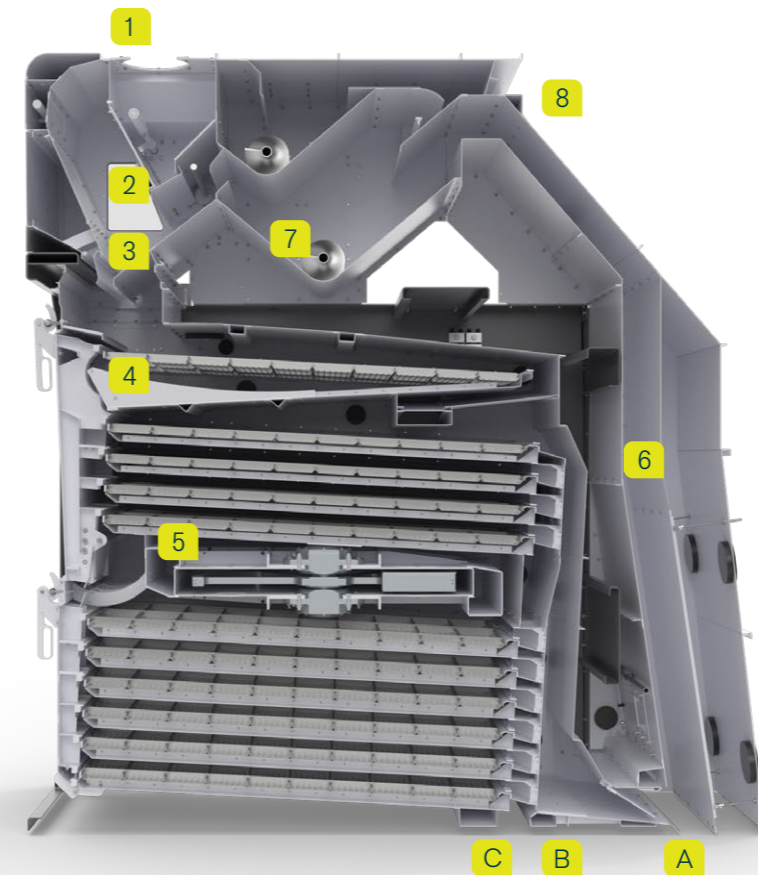

- 1 Product inlet
- 2 Vibrating inlet flap
- 3 Inlet aspiration
- 4 Product distribution onto sieves
- 5 Drive sieve box
- 6 Vertical sifter
- 7 Expansion chambers with discharge screws
- 8 Exhaust air connection

- A 1st grade
- B 2nd grade
- C Coarse particles

