

Connectivity for Bühler devices

Connect your Bühler equipment to Bühler Insights effortlessly with the Edge Gateway, simple installation and connection options.

This model comes in its own control cabinets for easy integration into existing networks.

The models comes with pre-configured software, making it quick and easy to connect to Bühler's digital services. Enjoy easy integration with the Edge Gateway.

Bühler Insights benefits

Uptime: Bühler Insights identifies common downtime causes and helps you take preventive actions

Quality: ensuring part quality through continuous process monitoring

Sustainability: less waste, reduced energy and water consumption through process optimization

Cost reduction: increased revenue trough higher availability of your equipment



Technical specifications

		Gateway
SAP ordering number		PADK-10527-001
IP rating		IP54
Installation requirements		Power Internet access
Connection options		WAN/Ethernet
Power supply		120/230 VAC, 50/60 Hz, 1 phase
Conformity		CE and UL certified
Operating temperature	°C	-5 to 40
Dimensions	mm	
Height		380
Width		600
Depth		350
Weight	kg	25
Mounting space required		
Width		888
Depth		840
Inventory		IPC with Bühler Insights Edge Agent for connectivity to Bühler Insights. Ethernet Switch 24 V power supply Industrial router, Westermo, for remote communication/Ethernet network connection

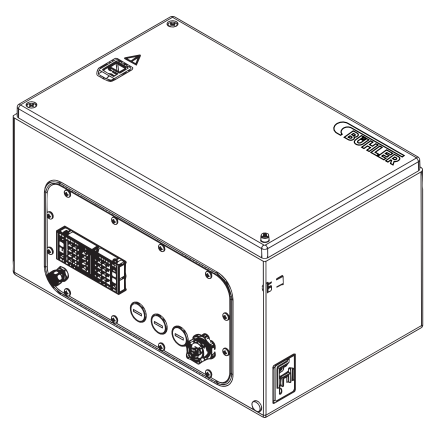
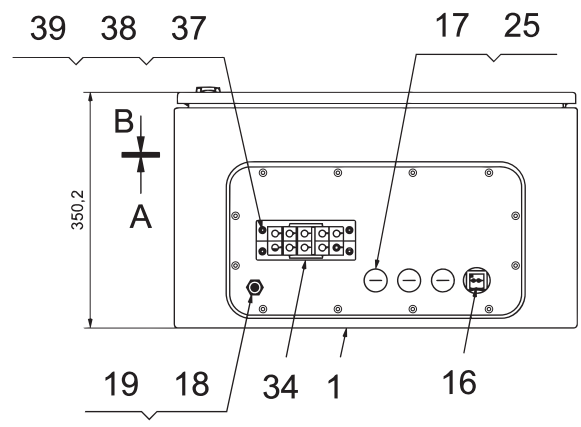
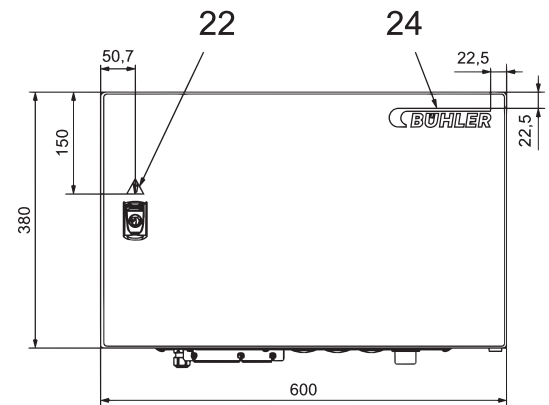

Bühler AG
 CH-9240 Uzwil, Switzerland T +41 71 955 11 11
 buhlergroup.com F +41 71 955 66 11

