

SmartPet

Pet Food Dryer

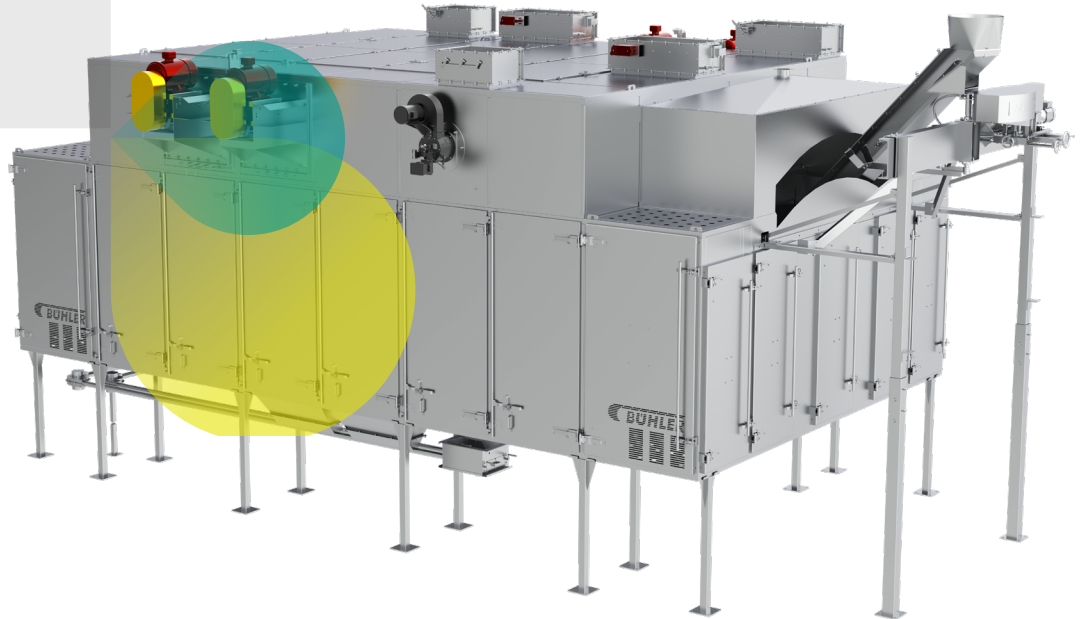

Uniform, efficient, and durable drying solutions for pet food

The new dual plenum SmartPet provides a superior airflow that results in uniform moisture content and greater saleable yield, and advanced hygienic design for cleaner operation.

Setting the standard for multi-pass, dual plenum conveyor dryers, the new SmartPet from Bühler features engineered airflow control throughout the recirculation loop. This unique design provides uniform airflow temperature and velocity distribution across the entire product bed, resulting in extremely consistent product quality. An additional benefit of this configuration is greatly improved fines management and collection, resulting in safer operation, ease of cleaning and increased uptime.

Sanitation and easy maintenance

Constructed from stainless steel, the new SmartPet provides full access to the dryer interior, allowing easy maintenance and cleaning, shortening downtime and increasing production. Innovative fines management provides a cleaner drying operation and further reduces cleaning downtime and risks of cross contamination or microbial growth.

The fully welded frame minimizes horizontal surface areas, preventing build up and further reducing sanitation concerns.

Heavy duty construction ensures safe, efficient, and reliable service

The new SmartPet features the heaviest gauge frame and bed-plates in the industry, providing extended production runs and hours of trouble-free operation. The dryer doors and panels contain 10cm of insulation, increasing energy efficiency. Modular construction provides quick installation and start-up.

Customer Benefits

- Higher saleable yields through increased product uniformity
- Energy efficient performance
- Easy-to-clean design reduces downtime
- Cleaner operation with innovative fines management system
- Operator-friendly control system

SmartPet conveyor dryer

Clean, uniform pet food processing

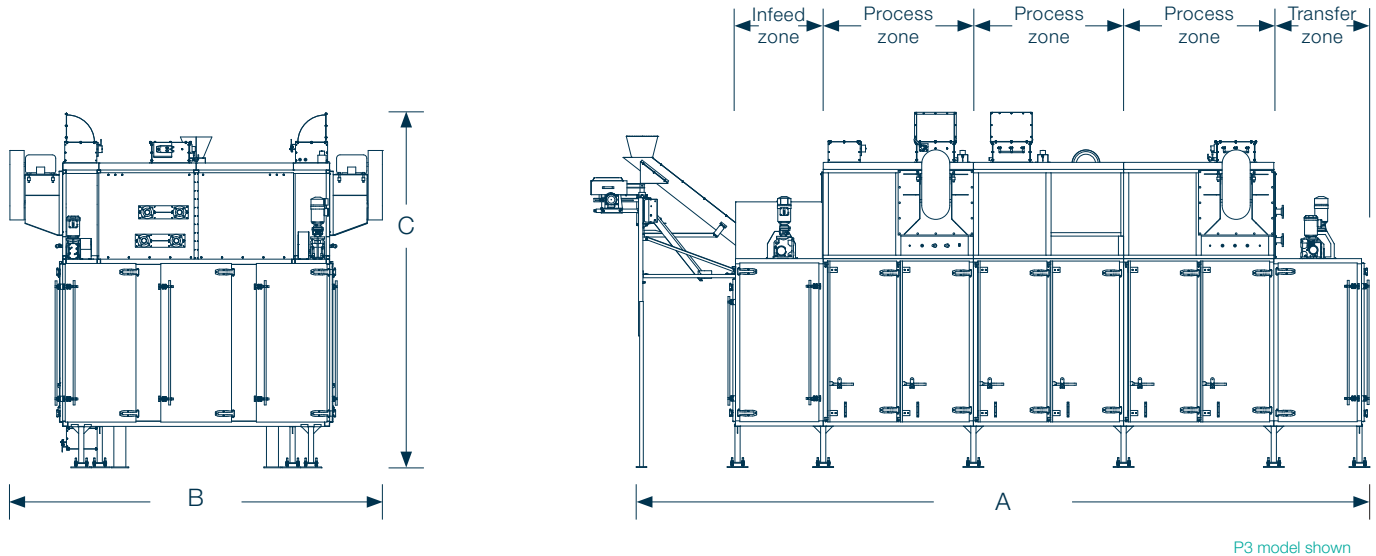

Technical Dimensions

	P3	P4	P5	P6	P7
Petfood Capacity (kg/hr discharge rate)					
gas heat	6,000	8,500	10,500	13,000	15,000
steam heat	5,000	7,000	9,000	11,000	12,500
Process zones	3	4	5	6	7
A - Length	10,550	12,735	14,920	17,105	19,290
B - Width	6,744	6,744	6,744	6,744	6,744
C - Height	5,533	5,533	5,533	5,533	5,533