

Carat
**Highest value
creation for
sophisticated
applications**

10,500 to 92,000 kN

For your most demanding applications **Die-casting solutions for complex parts**

Carat provides a complete die-casting solution for creating complex geometries and larger parts, to the tightest possible tolerances. Many of these sophisticated applications are found in the automotive industry for e-mobility parts, parts for the body-in-white and parts within the powertrain.

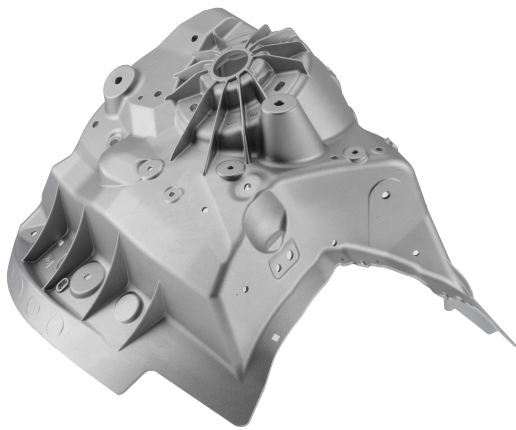

Traditional structural parts

The continuing quest for lighter-weight components in the automotive industry has seen the emergence of an attractive market – die-casting parts such as shock towers and longitudinal members as integrated structural parts.

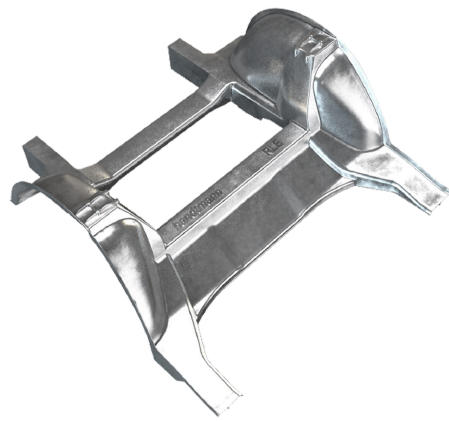

Megacastings

Megacasting one single part like a rear underbody or a battery case to replace many smaller parts offers groundbreaking opportunities for die casting. This includes freedom in design and the opportunity to integrate multiple functionality into one single part.



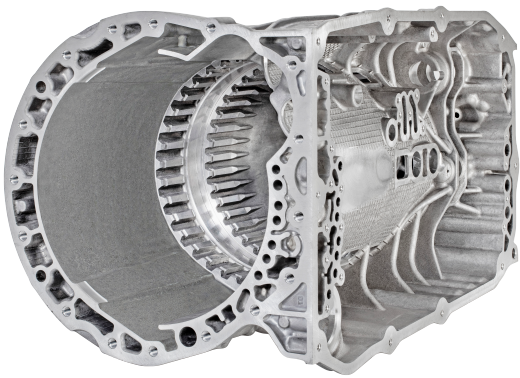

Powertrain components

EV and traditional automotive producers require the highest-quality components with full traceability. Aluminum and magnesium die-casting of engine blocks, gearbox housings (and many more) are perfect for these complex applications.



5G/6G communication infrastructure

Parts for communication – such as housings for 5G/6G antennas – require tight tolerances. The technology is set to drive mobile telecoms capability over the next few years.



Fully integrated solutions From melting to part handling – enabling higher productivity

Thinking about your entire production solution right from the start is key to enabling higher productivity in production. Bühler solutions are designed with this in mind – working towards our vision of 0% scrap, 40% less cycle time, and 24/7 uptime.

From a single machine to a fully integrated die-casting cell, we build customized solutions to meet your precise production needs. From initial engineering to fully commissioned on-site production, we will manage everything, taking responsibility for the project timeline and coordinating all relevant suppliers to guarantee delivery to planned timescales.

We offer a full range of production solutions – including entire cell automation – with all the relevant process steps from melting to part handling and beyond. One consistent operating concept delivers smoother handling, simpler maintenance, and improved productivity.

We can help integrate your die-casting cell into smart plant concepts too, analyzing your needs, running robot simulations for optimized processes and writing robot programs. And we'll support your Carat solution, 24/7, to ensure you get maximum productivity at all times.



SmartCMS – the brain of your solution

SmartCMS – the smart cell management system – takes integration to a new level by controlling all devices within the die-casting cell from one place. SmartCMS can increase productivity and traceability with improved product tracking through centralized data handling, monitoring and analysis.

Faster set-up and production changes, lower diagnostic time and effort, and Bühler Digital Services can all enhance efficiency and improve your cell OEE.

SmartCMS also ensures that your Carat solutions are ready for future integration with Industry 4.0 smart factory systems.





Performance you can trust

Flexibility built in

Your Carat two-platen die-casting solution with locking forces from 10,500 to 92,000 kN has flexibility built-in, enabling you to precisely adjust the die-casting process to fit your manufactured components and their properties.

6

1

Technology for the best casting results

Bühler's powerful and unique shot control, with closed-loop and real-time controlled injection, gives you reproducible casting results with a stable process that preserves the die.

2

Higher efficiency through two-platen technology

The patented platen design creates 25% less platen deflection, resulting in a high degree of dimensional accuracy for your castings.

3

Designed for ease of maintenance

A single point of access provides easy and safe maintenance on all machine sizes. Carat is designed for low maintenance input and reliable long-term production.

4

Modular energy frame for optimum usability

All the interfaces of the die connection are contained in a modular energy frame, making die changes and process settings easier, faster and safer.

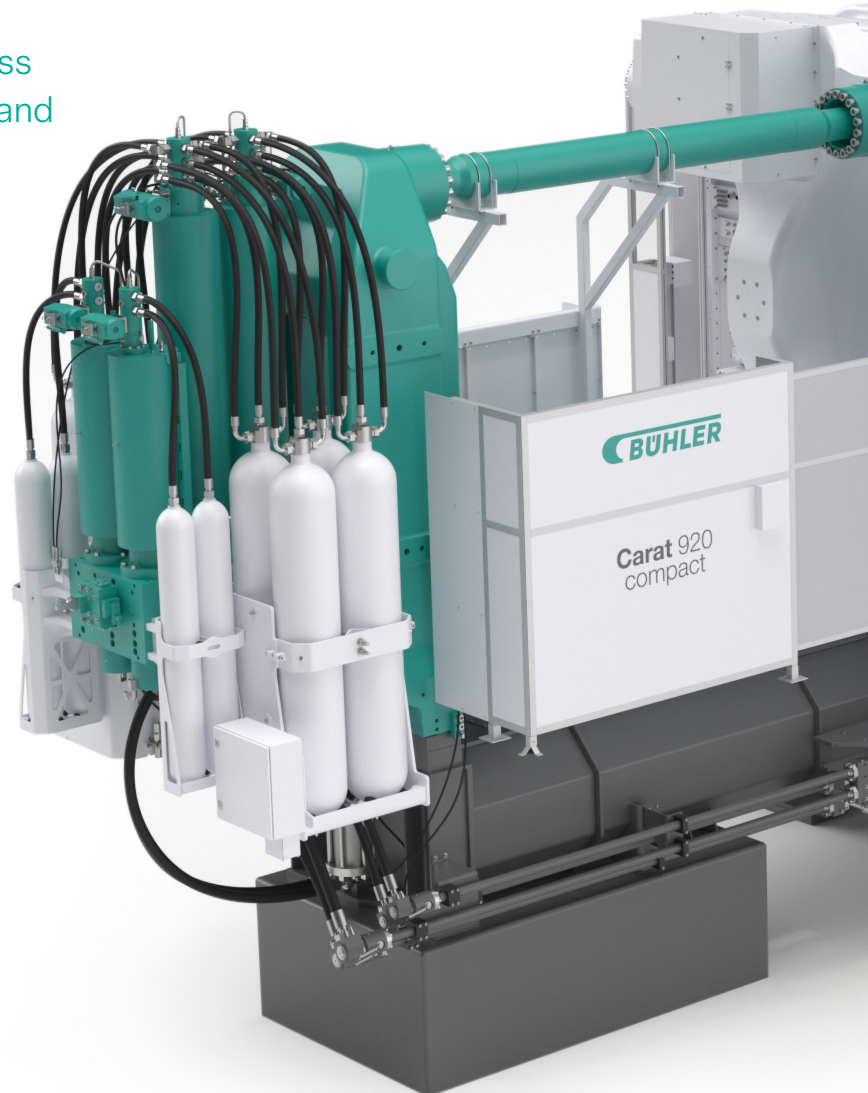

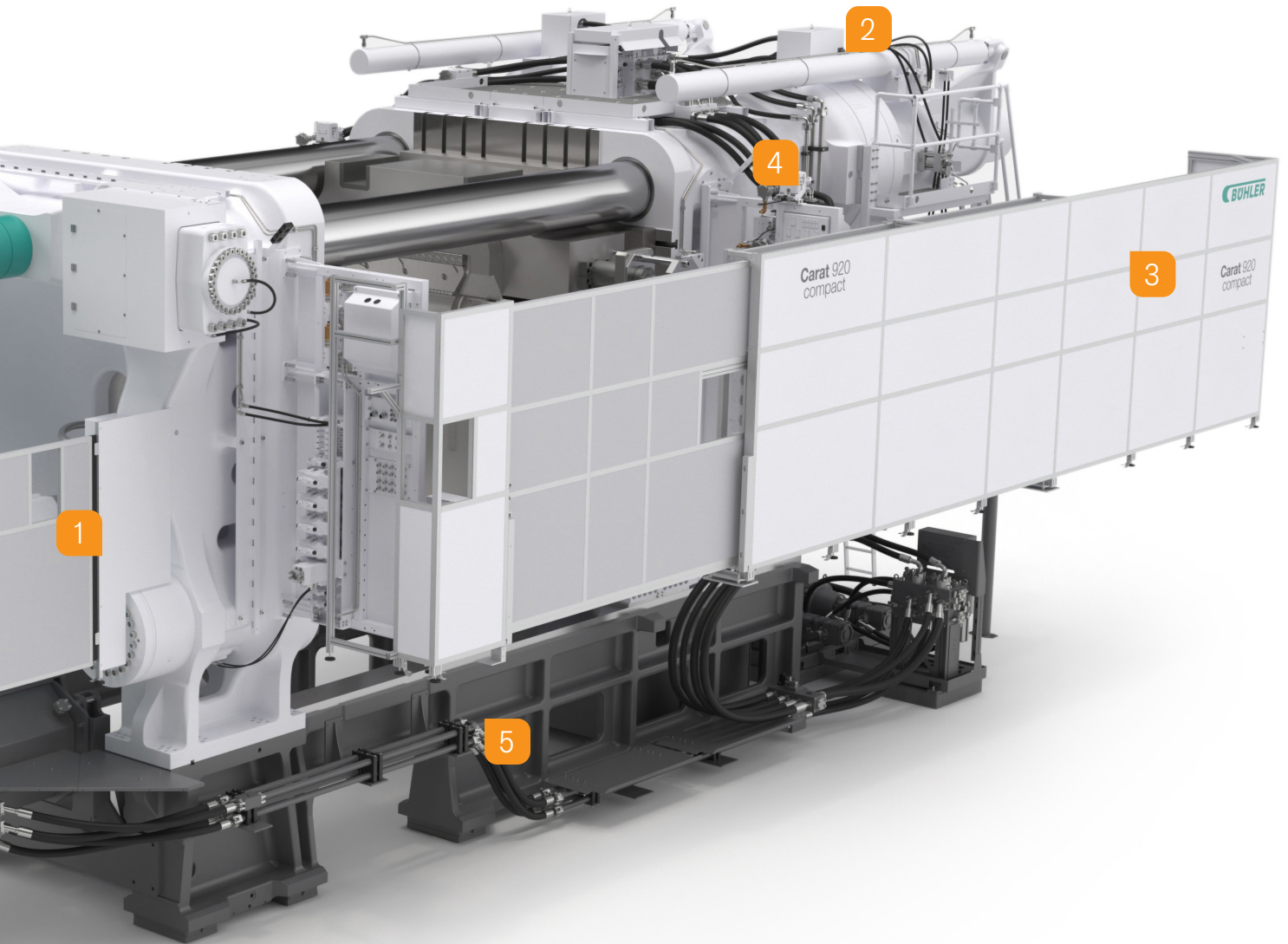

5

Intuitive DataView control system

DataView allows the peripherals in your cell to be centrally controlled and monitored. The system also monitors the cell and its processes in real time, and collects, analyzes, and stores production data for full traceability.

6

SmartCMS – Your operator in total control

SmartCMS allows you to view, control and program even very large and complex die-casting cells from one centralized user interface. It also enables connection with Industry 4.0 smart factory systems for even greater efficiency.

Proven innovation

Reliability, power, and quality



Unique injection unit improves productivity and reduces scrap

Bühler's unique real-time closed-loop die-casting technology gives you maximum quality and efficiency. Your die-casting process is continuously monitored and controlled in real time. The system automatically reacts and corrects deviations, leading to a high level of reproducibility and casting consistency that also helps to preserve your die. In addition, automated algorithms will help you to program optimal casting profiles, which results in shorter cycle times and higher part quality.

With numerous performance options and future upgrade paths, your Carat solution can be configured precisely for your needs, now and in the future.

Innovative DataView control system enhances availability

Available in multiple languages, DataView's intuitive graphical interface puts your operators in complete control. An overview of the die-casting machine and its integrated peripherals allows central control and monitoring of the cell from one interface.

The ability to coordinate the movement of peripheral devices, the machine and die, all at the same time, can shorten cycle times.

The system checks processes in real time and collects, analyzes and stores production data for each cycle to give you traceability. Efficient diagnostic systems work in the background, providing instant alerts to enable your operators to troubleshoot as soon as situations arise.

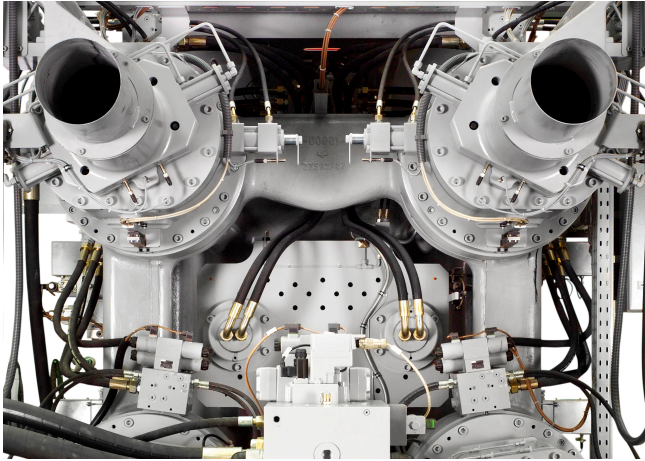

Higher efficiency through two-platen technology

The Carat two-platen solution with minimum deflection and a high degree of dimensional accuracy has long-proven its value producing large and complex structural components.

The compact design with a high rigidity reduces flash and delivers more stable production processes.

The stainless-steel coating for a hardened surface and corrosion protection extends the lifetime of the platen.

Carat is also equipped with the latest ServoDrive technology to make your production over 40% more energy-efficient.

Our vision is ...

0%
scrap

40%
less cycle time

24/7
uptime

...for the future
of die casting

Expertise you can rely on Bühler Die Casting services

Your Bühler die-casting solution comes with a Total Care service agreement which can be tailored to your needs and is designed to help you get the maximum from your die-casting cells.

Total Care can include:

- Regular inspections and recommendation for spare parts and maintenance work provided by our experienced specialists
- A choice of maintenance and support packages to complement the level of expertise you have in-house
- Remote support to always have expert help when needed
- Access to digital services to get more from your equipment
- Documentation of service and inspections on your myBühler account

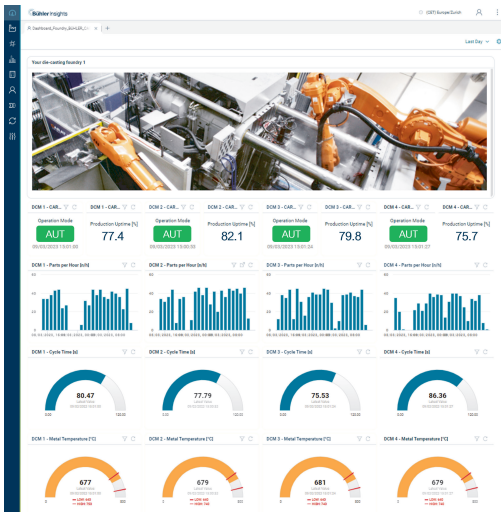

Die casting dashboard

Real-time data for you to keep an eye on your die-casting machine, foundry, and plant

Downtime analysis

The tool enables you to determine the cause of interruptions of your die-casting system – giving you help improving production

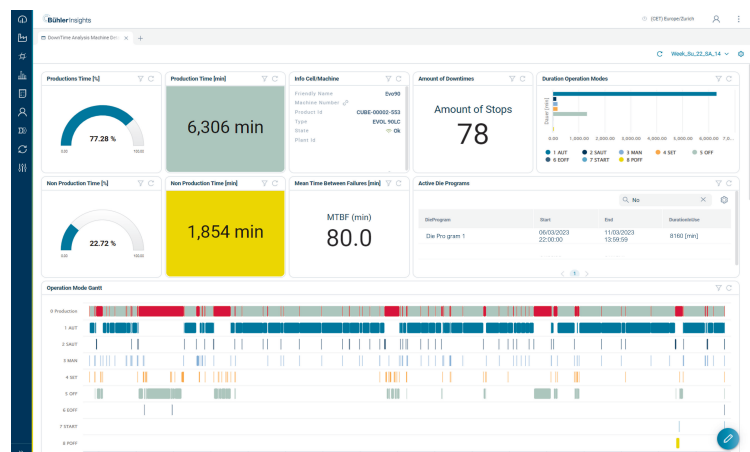



myBühler

myBühler gives you an overview of your Bühler equipment, including documents such as user manuals and spare part catalogs. This makes it easy to find the parts you are looking for.

Application technology & education

To get the most from your investment you need optimal performance of your die-casting cell. Our highly qualified staff can help with:

- A wide choice of training courses every year – at dedicated centers, online, or directly at your site.
- Process optimization to help drive up your OEE, from production start-up to fine-tuning during operation.
- Consulting to help you troubleshoot issues, consider future strategies and embrace industry trends.



Upgrades

Die casting is a demanding process and innovation constantly changes what's possible. It's good to know that as a Bühler customer, you have access to upgrades for machines and control units to always be up-to-date.

Carat

Technical data/dimension

Injection unit

Machine type	Injection force, dynamic (90% injection stroke)	Injection force, intensified	Plunger diameter (min./max.)	Shot weight (Al)*	Plunger stroke	Shot position	Projected area at 400 bar
	kN	kN	mm	kg	mm	mm	cm ²
105 lean	288	772	70/120	4.5/13.2	700	-50/-350	2625
105 compact	411	1099	80/140	7.1/21.8	850	0/-350	2625
105 extended	585	1537	100/160	13.7/35.2	1050	0/-350	2625
130 lean	288	772	70/120	4.5/13.2	700	-50/-350	3250
130 compact	411	1099	80/140	7.1/21.8	850	0/-350	3250
130 extended	585	1537	100/160	13.7/35.2	1050	0/-350	3250
140 lean	288	772	70/120	4.5/13.2	700	-50/-350	3500
140 compact	411	1099	80/140	7.1/21.8	850	0/-350	3500
140 extended	585	1537	100/160	13.7/35.2	1050	0/-350	3500
160 lean	411	1099	80/140	7.1/21.8	850	-70/-420	4000
160 compact	585	1537	100/160	13.7/35.2	1050	0/-420	4000
160 extended	816	2090	120/180	24.5/55.1	1300	0/-420	4000
180 lean	411	1099	80/140	7.1/21.8	850	-70/-420	4400
180 compact	585	1537	100/160	13.7/35.2	1050	0/-420	4400
180 extended	816	2090	120/180	24.5/55.1	1300	0/-420	4400
200 lean	411	1099	80/140	7.1/21.8	850	-70/-420	5000
200 compact	585	1537	100/160	13.7/35.2	1050	0/-420	5000
200 extended	816	2090	120/180	24.5/55.1	1300	0/-420	5000
220 lean	411	1099	80/140	7.1/21.8	850	-70/-420	5500
220 compact	585	1537	100/160	13.7/35.2	1050	0/-420	5500
220 extended	816	2090	120/180	24.5/55.1	1300	0/-420	5500
250 lean	585	1537	100/160	13.7/35.2	1050	-70/-490	6250
250 compact	816	2090	120/180	24.5/55.1	1300	0/-560	6250
250 extended	1171	3090	140/200	35.9/73.3	1400	0/-560	6250
280 lean	585	1537	100/160	13.7/35.2	1050	-70/-490	6875
280 compact	816	2090	120/180	24.5/55.1	1300	0/-560	6875
280 extended	1171	3090	140/200	35.9/73.3	1400	0/-560	6875
320 lean	585	1537	100/160	13.7/35.2	1050	-70/-490	8000
320 compact	816	2090	120/180	24.5/55.1	1300	0/-560	8000
320 extended	1171	3090	140/200	35.9/73.3	1400	0/-560	8000
350 lean	585	1537	100/160	13.7/35.2	1050	-70/-490	8750
350 compact	816	2090	120/180	24.5/55.1	1300	0/-560	8750
350 extended	1171	3090	140/200	35.9/73.3	1400	0/-560	8750
400 lean	816	2090	120/180	24.5/55.1	1300	-40/-600	10 000
400 compact	1171	3090	140/200	35.9/73.3	1400	0/-600	10 000
440 lean	816	2090	120/180	24.5/55.1	1300	-40/-600	11 000
440 compact	1171	3090	140/200	35.9/73.3	1400	0/-600	11 000
560 extended	1645	4295	170/240	64/128	1700	0/-700	14 000
610 extended	1645	4295	170/240	64/128	1700	0/-700	15 250
660 extended	1645	4295	170/270	64/162	1700	-200/-800	16 500
720 extended	1645	4295	170/270	64/162	1700	-200/-800	18 000
840 lean	1645	4295	200/300	89/200	1700	-150/-1000	21 000
840 compact	2137	5412	200/300	105/236	2000	0/-1000	21 000
920 lean	1645	4295	200/300	89/200	1700	-150/-1000	23 000
920 compact	2137	5412	200/300	105/236	2000	0/-1000	23 000

* Casting weight (Al) at min. / max. casting piston diameter and 67% filling level

Closing unit

Machine type	Maximum locking force	Platen size (height x width)	Distance between tie bars	Die height (min./max.)	Die opening stroke	Ejector force	Ejector stroke	Machine weight	Machine dims. incl. safety gates (l x w x h)
	kN	mm	mm	mm	mm	kN	mm	kg	m
105 lean	10 500	1600 x 1600	1000 x 1000	562/1150	1000	400	220	52 000	8.5 x 3.8 x 3.9
105 compact	10 500	1600 x 1600	1000 x 1000	562/1150	1000	400	220	51 000	9.0 x 3.8 x 4.0
105 extended	10 500	1600 x 1600	1000 x 1000	562/1150	1000	400	220	53 000	9.7 x 3.8 x 4.3
130 lean	13 000	1780 x 1780	1100 x 1100	640/1300	1100	400	220	58 000	8.9 x 4.0 x 4.0
130 compact	13 000	1780 x 1780	1100 x 1100	640/1300	1100	400	220	60 000	9.5 x 4.0 x 4.1
130 extended	13 000	1780 x 1780	1100 x 1100	640/1300	1100	400	220	63 000	10.2 x 4.0 x 4.4
140 lean	14 000	1780 x 1780	1100 x 1100	640/1300	1100	400	220	58 000	8.9 x 4.0 x 4.0
140 compact	14 000	1780 x 1780	1100 x 1100	640/1300	1100	400	220	60 000	9.5 x 4.0 x 4.1
140 extended	14 000	1780 x 1780	1100 x 1100	640/1300	1100	400	220	63 000	10.2 x 4.0 x 4.4
160 lean	16 000	2000 x 2000	1250 x 1250	724/1450	1250	500	240	85 000	10.4 x 4.3 x 4.2
160 compact	16 000	2000 x 2000	1250 x 1250	724/1450	1250	500	240	87 000	11.0 x 4.3 x 4.6
160 extended	16 000	2000 x 2000	1250 x 1250	724/1450	1250	500	240	89 000	11.9 x 4.3 x 4.5
180 lean	17 600	2000 x 2000	1250 x 1250	724/1450	1250	500	240	85 000	10.4 x 4.3 x 4.2
180 compact	17 600	2000 x 2000	1250 x 1250	724/1450	1250	500	240	87 000	11.0 x 4.3 x 4.6
180 extended	17 600	2000 x 2000	1250 x 1250	724 /1450	1250	500	240	89 000	11.9 x 4.3 x 4.5
200 lean	20 000	2240 x 2240	1400 x 1400	772/1600	1400	500	240	128 000	11.0 x 4.5 x 4.3
200 compact	20 000	2240 x 2240	1400 x 1400	772/1600	1400	500	240	130 000	11.7 x 4.5 x 4.7
200 extended	20 000	2240 x 2240	1400 x 1400	772/1600	1400	500	240	133 000	12.5 x 4.5 x 4.7
220 lean	22 000	2240 x 2240	1400 x 1400	772/1600	1400	500	240	128 000	11.0 x 4.5 x 4.3
220 compact	22 000	2240 x 2240	1400 x 1400	772/1600	1400	500	240	130 000	11.7 x 4.5 x 4.7
220 extended	22 000	2240 x 2240	1400 x 1400	772/1600	1400	500	240	133 000	12.5 x 4.5 x 4.7
250 lean	25 000	2480 x 2480	1550 x 1550	880/1800	1550	680	280	155 000	12.7 x 4.9 x 4.8
250 compact	25 000	2480 x 2480	1550 x 1550	880/1800	1550	680	280	158 000	13.5 x 4.9 x 4.9
250 extended	25 000	2480 x 2480	1550 x 1550	880/1800	1550	680	280	162 000	13.7 x 4.9 x 4.9
280 lean	27 500	2480 x 2480	1550 x 1550	880/1800	1550	680	280	155 000	12.7 x 4.9 x 4.8
280 compact	27 500	2480 x 2480	1550 x 1550	880/1800	1550	680	280	158 000	13.5 x 4.9 x 4.9
280 extended	27 500	2480 x 2480	1550 x 1550	880/1800	1550	680	280	162 000	13.7 x 4.9 x 4.9
320 lean	32 000	2750 x 2750	1700 x 1700	988/2000	1700	680	280	205 000	13.3 x 5.3 x 5.0
320 compact	32 000	2750 x 2750	1700 x 1700	988/2000	1700	680	280	209 000	14.2 x 5.3 x 5.0
320 extended	32 000	2750 x 2750	1700 x 1700	988/2000	1700	680	280	214 000	14.4 x 5.3 x 5.1
350 lean	35 000	2750 x 2750	1700 x 1700	988/2000	1700	680	280	205 000	13.3 x 5.3 x 5.0
350 compact	35 000	2750 x 2750	1700 x 1700	988/2000	1700	680	280	209 000	14.2 x 5.3 x 5.0
350 extended	35 000	2750 x 2750	1700 x 1700	988/2000	1700	680	280	214 000	14.4 x 5.3 x 5.1
400 lean	40 000	2970 x 2970	1800 x 1800	1044/2100	1800	1000	280	269 000	14.9 x 5.7 x 5.2
400 compact	40 000	2970 x 2970	1800 x 1800	1044/2100	1800	1000	280	273 000	15.1 x 5.7 x 5.2
440 lean	44 000	2970 x 2970	1800 x 1800	1044/2100	1800	1000	280	269 000	14.9 x 5.7 x 5.2
440 compact	44 000	2970 x 2970	1800 x 1800	1044/2100	1800	1000	280	273 000	15.1 x 5.7 x 5.2
560 extended	56 000	3580x3580	2200x2200	1300/2400	2200	1500	150	400 000	19.3 x 6.9 x 6.2
610 extended	61 000	3580x3580	2200x2200	1300/2400	2200	1500	150	400 000	19.3 x 6.9 x 6.2
660 compact	66 000	3690x3690	2300x2300	1300/2400	2200	1500	150	430 000	19.7 x 7.6 x 6.1
720 compact	72 000	3690x3690	2300x2300	1300/2400	2200	1500	150	430 000	19.7 x 7.6 x 6.1
840 lean	84 000	4180x4180	2500x2500	1500/2500	2500	2300	150	609 000	21.5 x 8.1 x 7.6
840 compact	84 000	4180x4180	2500x2500	1500/2500	2500	2300	150	620 000	21.4 x 8.1 x 7.6
920 lean	92 000	4180x4180	2500x2500	1500/2500	2500	2300	150	609 000	21.5 x 8.1 x 7.6
920 compact	92 000	4180x4180	2500x2500	1500/2500	2500	2300	150	620 000	21.4 x 8.1 x 7.6

Subject to change without notice.

Carat

Technical data / dimension

Machine type*	MA	MB	MC	MD	ME	MF	MG	MH	MI	MJ min.	MJ max.	MK	ML	MN	MO	MP	MQ
105	1375	3670	440	9047	2900	1401	1920	1922	1940	1590	1940	3965	847	3204	1601	1374	6895
130	1565	3920	480	9487	2900	1401	2020	2022	2042	1692	2042	4067	847	3398	1729	1444	7593
140	1565	3920	480	9487	2900	1401	2020	2022	2042	1692	2042	4067	847	3398	1729	1444	7593
160	1410	4845	525	11 037	3035	1302	2170	2172	2200	1780	2200	4556	856	3696	1861	1815	8576
180	1410	4845	525	11 037	3035	1302	2170	2172	2200	1780	2200	4556	856	3696	1861	1815	8576
200	2030	4845	580	11 657	3035	1302	2270	2270	2340	1920	2340	4696	856	3975	1999	1945	9418
220	2030	4845	580	11 657	3035	1302	2270	2270	2340	1920	2340	4696	856	3975	1999	1945	9418
250	1725	6005	640	13 498	3191	1260	2470	2470	2526	1966	2526	4872	882	4386	2139	1910	10 603
280	1725	6005	640	13 498	3191	1260	2470	2470	2526	1966	2526	4872	882	4386	2139	1910	10 603
320	2405	6005	725	14 178	3191	1260	2670	2670	2696	2136	2696	5002	882	4718	2302	2045	11 619
350	2405	6005	725	14 178	3191	1260	2670	2670	2696	2136	2696	5002	882	4715	2302	2045	11 619
400	2405	6595	790	15 110	3359	1226	2870	2870	2876	2276	2876	5219	910	5033	2436	2180	12 470
440	2405	6595	790	15 110	3359	1226	2870	2870	2876	2276	2876	5219	910	5033	2436	2180	12 470
560	3490	7890	955	19 286	3790	1176	3470	3470	3593	2893	3593	6228	1315	6170	3085	3085	14 880
610	3490	7890	955	19 286	3970	1176	3470	3470	3593	2893	3593	6228	1315	6170	3085	3085	14 880
660	4300	7430	1325	19 700	3970	1342	3822	3822	3679	2879	3479	6100	1209	6750	3330	3330	14 350
720	4300	7430	1325	19 700	3970	1342	3822	3822	3679	2879	3479	6100	1209	6750	3330	3330	14 350
840	4609	8070	1720	21 480	4093	1285	3890	3890	4400	3400	4250	7566	1754	7630	3495	3495	15 455
920	4609	8070	1720	21 480	4093	1285	3890	3890	4400	3400	4250	7566	1754	7630	3495	3495	15 455

Units in mm

* Data based on type Carat compact

Subject to change without notice.

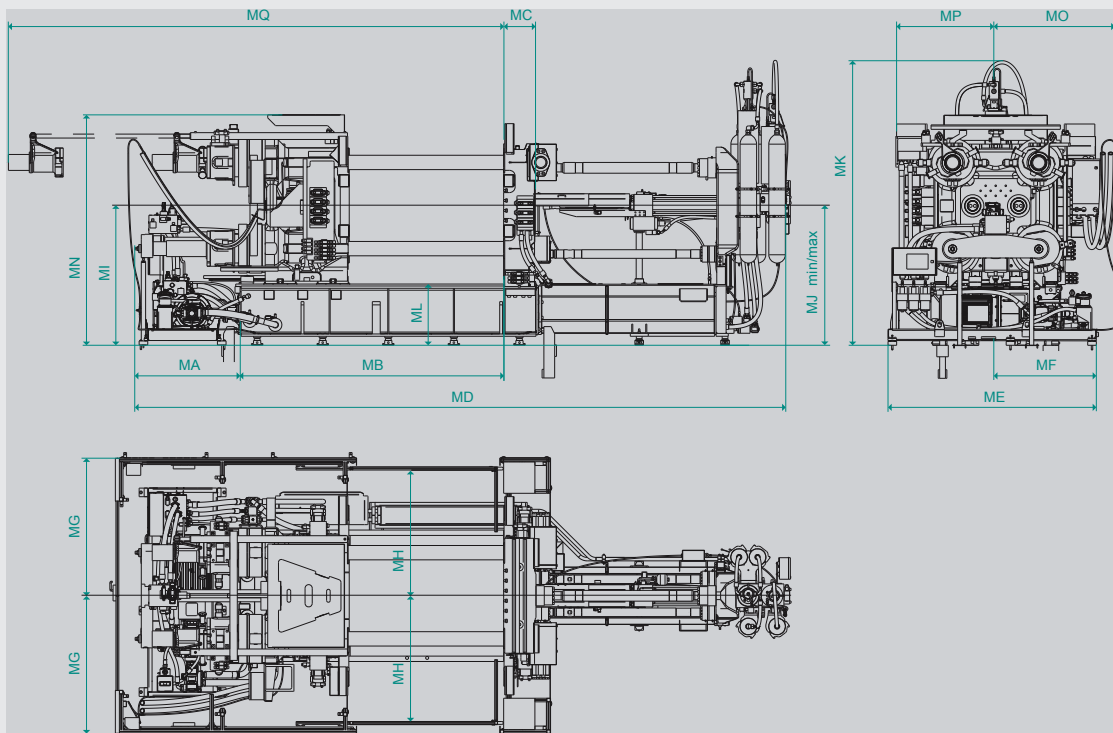

A photograph of three people in a factory setting. A man in a black polo shirt and jeans is pointing at a large industrial machine. Two other people, a man and a woman, are looking at the machine. The machine is white and has several large cylindrical components. The background shows a factory floor with yellow safety lines and other equipment. A large, semi-transparent pink and teal graphic is overlaid on the right side of the image, containing the text.

**Each Carat
solution is tailored
to your individual
requirements**



Brochure Carat EN 1225 254514

Bühler AG

CH-9240 Uzwil
Switzerland

T +4171955 11 11

die-casting@buhlergroup.com
buhlergroup.com/die-casting